



HR24A

Compact Undercounter Reach-in Refrigerator



HR24A
02/01/17
Item # 13278

W x D x H
23.4" x 24.5" x 32.7"*
*with legs

HR24A ★



FOR GENERAL REFERENCE ONLY
Models shown may not match the
model features or manuf year of the
item offered by AERE.

Features

- ▶ **Stainless steel exterior front, sides and top**
- ▶ **UL approved for outdoor use**
- ▶ **Energy efficient, one piece ABS interior liner**

- Door is stainless steel exterior, aluminum interior and is field reversible
- Magnetic door gasket is easily removable for cleaning
- Environmentally friendly cyclopentane insulation
- Electronic controls with LED Temperature Display and Audio/Visual Alarm
- High and low temperature alarms as well as "Door Open" alarm
- Ducted air flow for even air distribution throughout the cabinet
- Cylinder door lock with keys
- Automatic defrost
- (3) Epoxy coated shelves standard
- Built-in cabinet installation with louvered trim
- Three year parts and labor warranty

Dimensions / Capacity

One Section HR24A

Interior Storage Capacity (CF) (AHAM)	4.0 ft ³
Overall Width x Depth (including 1" bumper)	23.4" x 24.5"
Height (including legs)	32.7"
Depth with Door Open at 90°	51.5"
Adjustable Shelves	3
Shelf Dimensions (W x D)	(1) 19.13" x 17", (2) 19.13 x 12"
Crated Weight	102 lbs.

Electrical / Refrigeration

One Section HR24A

Voltage	115/60/1
HACR Breaker	15.0 Amps ⓘ
Electrical Connection (NEMA)	5-15P
Voltage Range	104-127
Ambient Temp. Range	60° to 95°F
Control Setpoint Range	34° to 50°F
Amperage	2.0
Energy Consumption (kWh/day) @ASHRAE	.378
Refrigerant	R-134a

Options

- Epoxy Shelves
- Glass Shelves

Warranty

- * 3 Year - parts and Labor on entire machine.

Valid in United States, Canada, Puerto Rico and U.S. Territories. Contact factory for warranty in other countries.



HR24A

Compact Undercounter Reach-in Refrigerator



HR24A
02/01/17
Item # 13278

FRONT VIEW

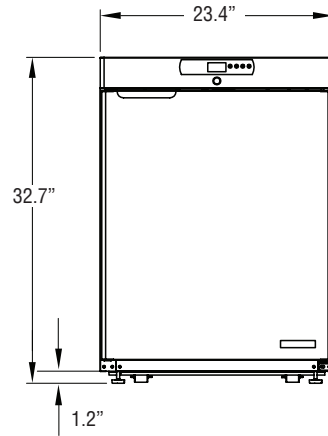

PLAN VIEW

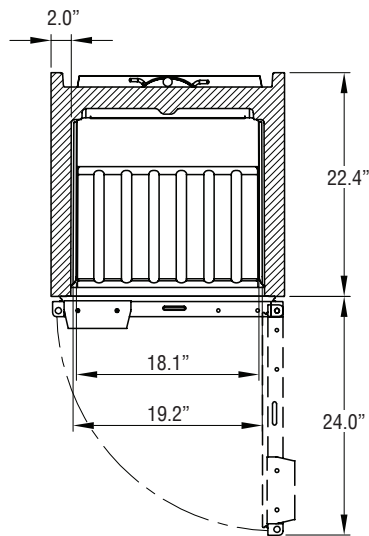

BACK VIEW

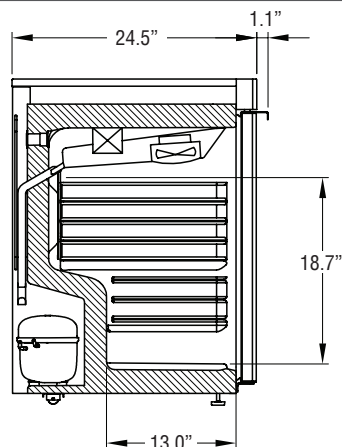

Printed in the U.S.A.